



Tension2 Electric Screen  
CineTension2 Series  
Ver.1.5  
Users Guide





# Accessory for Cine Tension2

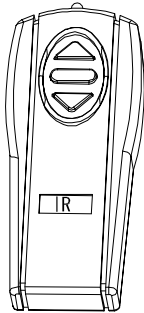

① IR

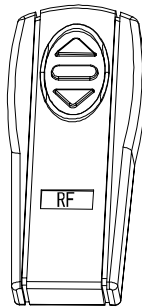

② RF

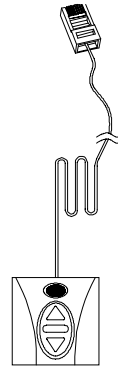

③ Wall box

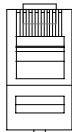

Red 12V | Green 0V

④ 12V trigger

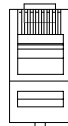

⑤ Eye receiver

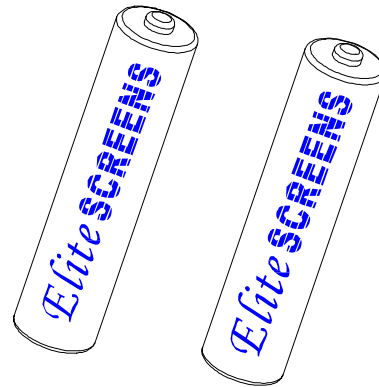

⑥ Battery

Please always point to the eye receiver when using the IR remote

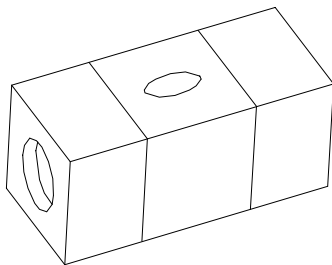

⑦ Bubble level



## Important Safety and Warning Precautions

1. Be sure to read this manual before use and follow the procedures specified:

- ☆ Please retain this manual for future reference.
- ☆ To avoid any damage, do not use any accessories not recommended by the manufacturer.
- ☆ Handle the device carefully during transportation to avoid impact.
- ☆ Do not put the device on uneven or inclined surfaces.
- ☆ Do not put heavy objects on the power cord; affix the power cord properly to avoid someone tripping over it.
- ☆ Never overload the power cord to prevent electrical shock or fire.
- ☆ Guard the device from any liquid or foreign object to avoid electrical shock or fire due to loose contact or short circuit.

2. If any accessories need to be replaced, be careful to avoid short circuit.

3. There are no user serviceable parts in the device. Nobody except authorized technicians can open this device. To prevent the risk of electrical shock or fire, protect against moisture and rain.

Make sure that the power source this device is connected to has a continuous power flow.

The rating label on the product indicates the rated voltage.

Do not handle the power plug when your hands are wet or your feet are in contact with water.

4. Do not use this device under the following circumstances:

- 1) Disconnect the power cord under the condition of heavy wind, rain, thunder or lightning.
- 2) Avoid direct sunshine, rain shower or moisture.
- 3) Keep away from fire sources and high temperature to prevent this device from overheating.
- 4) Cut off the power supply first before transportation or maintenance.



## Warning

Individual modifications to this product are prohibited and will void the user's warranty. Please contact the Service Department for any questions.

### **NOTE:**

This equipment has been tested and found to comply with the limits for a Class B digital device, pursuant to Part 15 of the FCC Rules.

These limits are designed to provide reasonable protection against harmful interference in a residential installation. This equipment generates uses and can radiate radio frequency energy and, if not installed and used in accordance with the instructions, may cause harmful interference to radio communications.

However, there is no guarantee that interference will not occur in a particular installation. If this equipment does cause harmful interference to radio or television reception, which can be determined by turning the equipment off and on, the user is encouraged to try to correct the interference by one or more of the following measures:

To ensure safe and reliable operation, direct connection to a properly grounded power source is advised.

The power outlet supplying power to the unit should be close to the unit and easily accessible

- ✎ Reorient or relocate the receiving
- ✎ Increase the separation between the equipment and receiver.
- ✎ Connect the equipment into an outlet using a circuit different from where the receiver is connected
- ✎ Consult the dealer or an experienced radio/TV technician for help.



# Control System

**1. 12V Trigger:** 12V trigger for your new Elite Cinetension-----allows your screen to synchronize its drop and rise with the projector's power cycle. The screen drops when the projector powers up and retracts when the projector powers down.

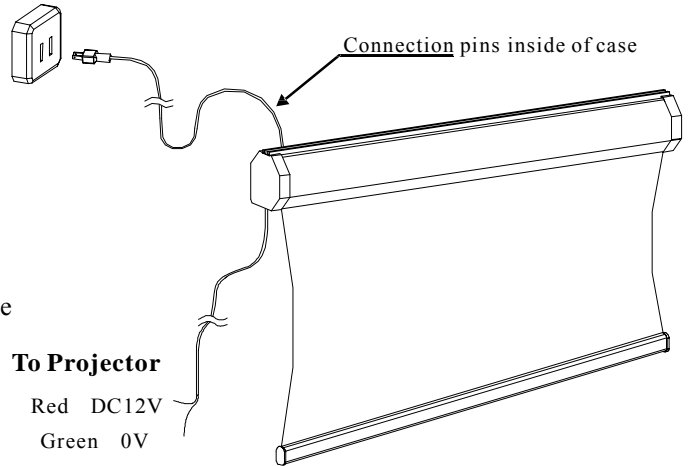

## Video Projection Interface

**2. IR (Infrared) Wall Box Kit and Eye Receiver:** The Wall Box Kit contains an IR receiver and enables the consumer to use either the IR remote or hardwire controls to operate the screen's drop/rise capabilities. IR eye protrudes from the bottom of the casing to present a low profile line-of-sight control option for your IR remote. It is a low-visibility alternative to using the wall box kit and its ability to protrude from the bottom of the screen allows line-of-sight control even in a recessed ceiling install at ion.

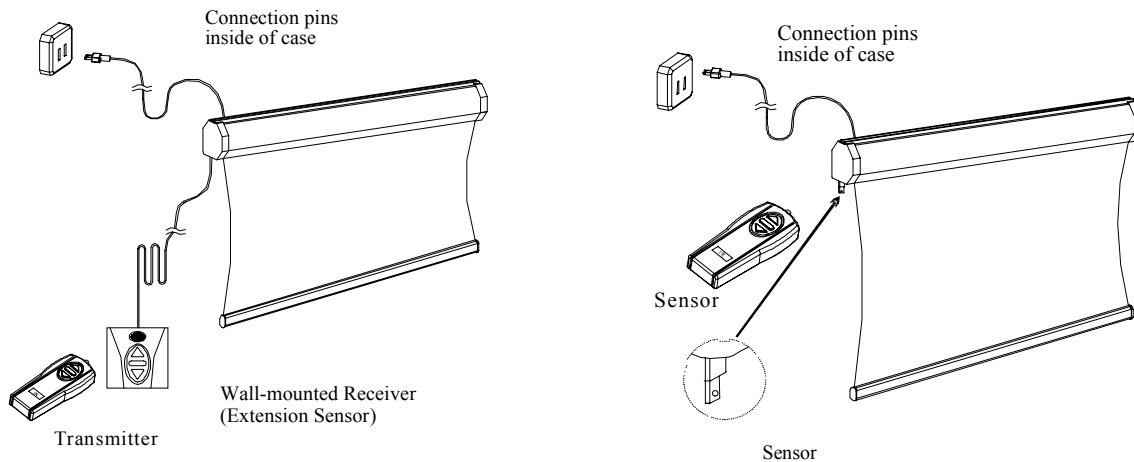

**3. Bubble Level:** Included with the installation package is a small bubble level that can be useful in determining if the screen is perfectly level when installing.

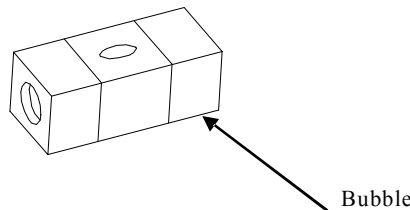

- NOTE :**
- ① Please use the Down sign side as the bottom.
  - ② The Bubble should be in the middle position to determine that it is level.



## IMPORTANT SAFETY INSTRUCTIONS

*Please read this guide prior to installation.*

- Make sure the current rating is equal to that of the appliance rating when an extension cord is used.
- Do not use any accessories not provided by the manufacturer with this screen. We will not be responsible for any risks of fire, electric shock, or injuries resulting from the misuse of this product with accessories not designed for use with this product.
- Make sure the screen is mounted in a horizontal level position. We suggest consulting with a professional if you are unsure on how to perform a proper installation.

### INSTALLATION

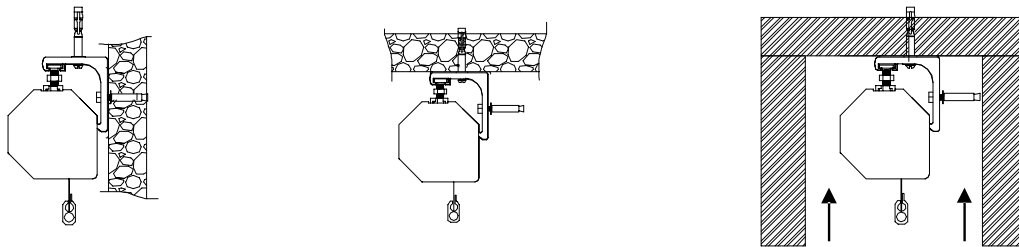

*\*Allow 2" of spacing between the front and back of the screen casing.*

- Masonry Anchors are used on concrete/masonry wall/ceilings; Plastic drywall anchors are included for drywall mounting.
- Wood screws are to be used for wooden wall/ceiling studs on screen sizes less than or equal to 120" inches (diagonal). Masonry anchors should be used for wall/ceiling installations of screen sizes greater than 120" inches (diagonal).
- Install the Aluminum Extruded Hanger set onto the slide channel and move to the desired position before locking it by tightening the connecting bolt.

### MOUNTING ACCESSORIES

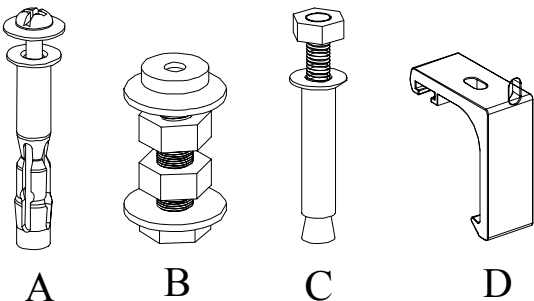

Upon assembly the bracket will slide into the casing rails for mounting.

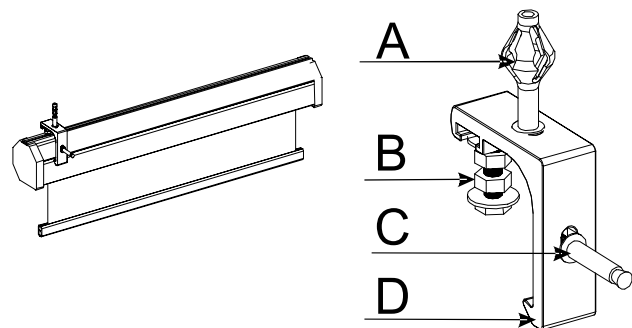

**Warning:** Standard screws x 2 for each type

These are standard accessories included with the ceiling/wall brackets. Models may vary and anchors will not support all models.



# Power Cables and controls

The IR receiver will be connected from the screen

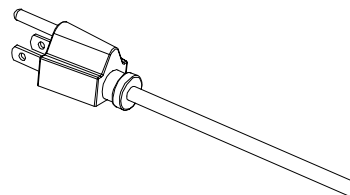
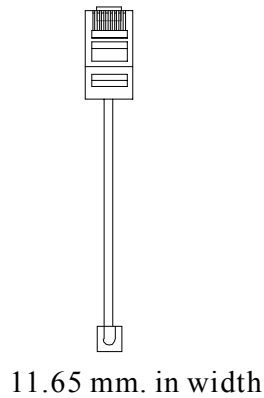
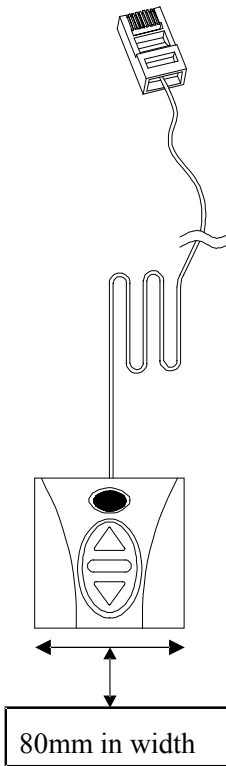

The 3 prong cable will be connected from the outlet to the case.

Although the IR remote requires a direct line of sight with the IR sensor to function, the case can be hidden from sight and operated using the RF remote. When depressing the directional buttons you should hear a faint click signifying that the mechanism is working properly.

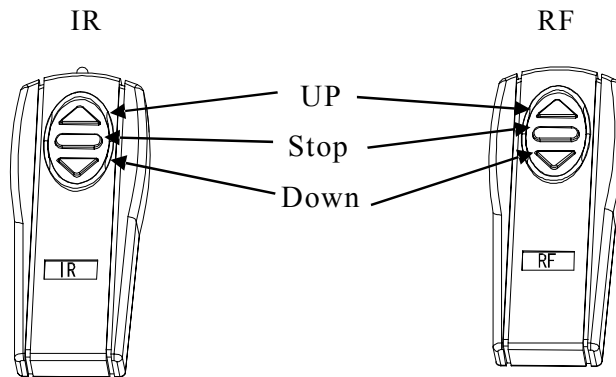

This is the **IR** (Infra-Red) remote with a range of 15 Ft. Battery size AAA

This is the **RF** (Radio Frequency) remote with a range of 30 Ft. Battery size AAA

\*\* Please remember to always point to the wall switch receiver when using the IR remote. The IR remote can also work with a Universal Learning Remote Control usually by programming the Screens IR codes into your Universal Learning Remote.



**FOR REFERENCE ONLY:**

## Tension Screen Adjustment

(Attention: This adjustment is not required. The screens tension has been set to achieve its best performance. Always contact an Elite Screen Technician for assistance to avoid damaging the screen and voiding your warranty.)

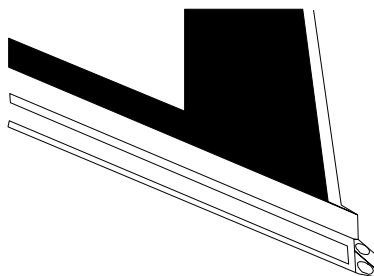

Pulling the knob and turning it Clockwise it will create more tension to the screen. By pulling the knob Counter-clockwise it will start to release tension

## Trouble Shooting

If the electric screen does not move, please check the following:

1. Check the power supply first. The screen will understandably not move without power.
2. Make sure the power cord is firmly plugged to the power outlet.
3. Make sure that all cable connections are secure.
4. If the screen works well with the line switch but not with the remote control, please make sure the remote controls have fresh batteries or replace them with new ones. Change the battery every 6 Months to ensure proper operation of the remotes.
5. For all other problems, please contact Elite Screens at [Techsupport@elitescreens.com](mailto:Techsupport@elitescreens.com)  
Or call 1-877-511-1211 Ext.202/234.



## FAQ's

1. Q: Why does my screen no longer function?

A: There are a few possible things you could check:

A.) Make sure your wall plug has power and that the screen is properly plugged in.

B.) Please check the fuse to your screen. (Call Tech support for location of fuse)

C.) If screen works well with the line switch but not with the remote control, make sure the remote control has good batteries in it.

D.) Our electric screens with a tubular motor installed are equipped with a Thermal relay. This would include all Home (2, 3), Tension (1, 2, 3) series, and VMAX screens with a diagonal size above 180". This feature will automatically shut off screen in the event the motor becomes too hot, preventing overheating of the motor. To correct this, let screen alone for 10-15 minutes and try again.

2. Q: How is the screen material cleaned?

A: The screen material can be cleaned with mild soap and water.

3. Q: What type of batteries do the remote controls require?

A: The IR and RF remote controls use AAA alkaline batteries

4. Q: Can you manually pull down the screen?

A: No, manually pulling down the screen will damage the electronic motor rolling system.

5. Q: How could I setup my Screens IR receiver to work with my learning remote control system? Do you have any IR codes I can use to achieve this?

A: Our IR remote controls have been evaluated and entered in to the databases of some Universal remote control manufacturers. Please contact the manufacturer of your remote to inquire about your remotes ability to function with ours. If they have not evaluated our remote control then the following list of Binary codes will be used for most remote setups.

For Spectrum, VMAX2 (Plus), Home2(3) and Tension2(3) Series

Up: 1111 0000 0001

Stop: 1111 0000 0010

Down: 1111 0000 0100

6. Q: What is the gain on the matte white screen material?

A: The matte white material has a gain of 1.1. For detailed specs, info please check our web-site for more detail

Note: For more Update FAQ, please visit [www.elitescreens.com](http://www.elitescreens.com)



## Warranty Policy - Electric Screens

Two (2) year warranty parts and labor from purchase date as follows (except for refurbished units as specified below):

Refurbished units carry a 90-day parts and labor warranty.

Demo units or open box items are AS IS items and do not carry a warranty.

Each party will be responsible for one way shipping during the warranty period.

DOA (Defective On Arrival): Must be reported within 7 business days of receipt. An RMA (Return Merchandise Authorization) number must be issued in order to process a replacement. Elite Screens will replace the DOA (Defective On Arrival) unit with a brand new replacement \*(see exceptions below) after the DOA unit is received and/or confirmed defective. Once the product is received, Elite Screens will send out a new\* unit to the customer by ground service (based on stock availability). Should a problem be reported after the 7-day grace period, the item must be shipped to us for warranty repair.

Missing Parts must be reported within the 7-day (DOA) grace period. If reported after 7 days, customer will be only responsible for shipping and handling fees. If reported after 30 days of receipt, customer is responsible for cost of the parts and shipping & handling fees.

\*A new or refurbished replacement will be sent out to the customer depending on the type of purchase (new or refurbished) or based on stock availability.

**Please do not return** any unauthorized items to Elite Screens, as they will be refused.

The RMA number must be included on the outside label of your shipping box and shipping documents. Our warehouse is not authorized to accept returns without an RMA number on the shipping label. RMA numbers are valid for 45 days from the date of issue.

## Warranty Policy-Damages

- All shipping damages must be reported within 7 business days upon receipt of the Product. After 7 days Customer is responsible for all incurred costs
- Inspect all shipments upon arrival. If damage or loss is apparent upon delivery do not accept the shipment until you make a notation of the damage on all copies of the carrier's delivery receipt and have the driver sign all copies to acknowledge the damage. Do not sign a clear receipt for damaged or missing items or there will be no basis for a claim. Ask the carrier to make a detailed inspection of the damage. File a claim with the carrier. Cooperate and follow up as necessary to secure final settlement
- Immediately advise Elite Screens of all damages or problems. Do not return merchandise to Elite Screens. File your claim with the carrier enclosing copies of the bill of lading (signed by the driver) and inspection report as support. Keep all packing materials and boxes with the damaged product. DO NOT throw any thing away. Although Elite Screens will provide any assistance possible we can not be responsible for the actual filing of claims on the carrier or accept liability for non-collectable freight claims

For Warranty and Service requests please fill out a RMA /Service Form at:

[http://www.elitescreens.com/service\\_form.htm](http://www.elitescreens.com/service_form.htm).

Please Visit this link for full Warranty information:

<http://www.elitescreens.com/service.htm>

For Customer Service and Technical questions, please contact Elite Screens at:

Telephone:(877)-511-1211 Fax:(562)-483-8498

[www.elitescreens.com](http://www.elitescreens.com) / [eliteinfo@elitescreens.com](mailto:eliteinfo@elitescreens.com)



# REGISTER YOUR ELITE PRODUCT

## Two ways to register your warranty with Elite Screens Inc.

A. Online (Faster and Easier) [www.elitescreens.com/register.htm](http://www.elitescreens.com/register.htm)

B. Fill out & Fax to (562) 4 83-8498, Attn: Customer Service Dept.

\*Your Name: \_\_\_\_\_

Address: \_\_\_\_\_

City/State/Zip \_\_\_\_\_

\*Email Address: \_\_\_\_\_

\*Phone: \_\_\_\_\_

\*Screen Model: \_\_\_\_\_

\*Serial Number: \_\_\_\_\_

\*Date of Purchase: \_\_\_\_\_

\*Dealer / Reseller Purchased from (name of the reseller): \_\_\_\_\_

What is your Projector Model: \_\_\_\_\_

Application:  Home  Education  Corporation  Government  
 Others

How would you rate this screen?  Excellent  Good  Ok  Improvement needed

Comments:

\_\_\_\_\_  
\_\_\_\_\_  
\_\_\_\_\_

**If you have pictures of your screen you'd like to share with us, please email your pictures to:**

[Eliteinfo@elitescreens.com](mailto:Eliteinfo@elitescreens.com)

**Or call us at 877-511-1211 Sales and Marketing Div.**

For any technical inquiries, please email to [techsupport@elitescreens.com](mailto:techsupport@elitescreens.com) or 877-511-1211 Customer Service Div

For any warranty claim inquires, please email to [rma@elitescreens.com](mailto:rma@elitescreens.com) or 877-511-1211 Customer Service Div.

[www.elitescreens.com](http://www.elitescreens.com) / [eliteinfo@elitescreens.com](mailto:eliteinfo@elitescreens.com)



### Elite Screens - CineTensipon 2 & 3 Dimension Table

Unit: Inch

CineTension Model	Case L (A)	Screen W (A1)	View W (A2)	Bottom Edge (B4)	Screen H (TTL) (B2)	View H (B3)	Overall H (B1)	Overall H w/ bracket (B)	Case Height (B5)	Case W (C)	Case End to Screen (C1)	G1	G2	G3	G4	G5	G6	G7	G8
84H	88.46	80.23	73.23	3.43	50.43	41.18	54.76	56.34	3.70	382	0.79	2.76	1.46	0.87	0.47	2.89	1.57	0.79	0.39
92H	96.06	87.20	80.20	3.78	54.88	45.12	60.20	62.17	4.57	504	0.94	3.43	1.85	1.38	0.69	4.06	2.17	0.79	0.39
100H	103.03	94.17	87.17	3.78	58.62	49.02	64.09	66.06	4.57	504	0.94	3.43	1.85	1.38	0.69	4.06	2.17	0.79	0.39
106H	109.05	99.40	92.40	3.78	61.57	51.97	67.05	69.02	4.57	504	0.94	3.43	1.85	1.38	0.69	4.06	2.17	0.79	0.39
120H	122.60	111.61	104.61	3.78	66.46	58.82	71.89	73.86	4.57	504	0.94	3.43	1.85	1.38	0.69	4.06	2.17	0.79	0.39
135H	135.47	124.68	117.68	3.78	73.82	66.18	79.25	81.22	4.57	504	0.94	3.43	1.85	1.38	0.69	4.06	2.17	0.79	0.39
150H	149.76	137.79	130.79	3.78	81.18	73.54	86.61	88.58	4.57	504	0.94	3.43	1.85	1.38	0.69	4.06	2.17	0.79	0.39
84V	82.44	74.17	67.17	3.43	59.65	50.39	63.98	65.55	3.70	382	0.79	2.76	1.46	0.87	0.47	2.89	1.57	0.79	0.39
100V	96.02	87.00	80.00	3.78	69.61	60.00	75.03	76.97	4.57	504	0.94	3.43	1.85	1.38	0.69	4.06	2.17	0.79	0.39
120V	113.46	102.98	95.98	3.78	79.61	71.97	85.04	87.01	4.57	504	0.94	3.43	1.85	1.38	0.69	4.06	2.17	0.79	0.39
135V	125.47	114.99	107.99	3.78	88.62	80.98	94.06	96.02	4.57	504	0.94	3.43	1.85	1.38	0.69	4.06	2.17	0.79	0.39
150V	138.23	127.00	120	3.78	97.64	90.00	103.07	105.04	4.57	504	0.94	3.43	1.85	1.38	0.69	4.06	2.17	0.79	0.39

Unit: mm

CineTension Model	Case L (A)	Screen W (A1)	View W (A2)	Bottom Edge (B4)	Screen H (TTL) (B2)	View H (B3)	Overall H (B1)	Overall H w/ bracket (B)	Case Height (B5)	Case W (C)	Case End to Screen (C1)	G1	G2	G3	G4	G5	G6	G7	G8
84H	2247.00	2037.84	1860.04	87.00	1281.00	1046.00	1391.00	1431.00	94.00	97.00	20.07	70.10	37.08	22.10	11.94	73.41	39.88	20.07	9.91
92H	2440.00	2214.88	2037.08	96.00	1394.00	1148.00	1529.00	1579.00	116.00	128.00	24.00	87.00	47.00	35.00	17.50	103.00	55.00	20.07	9.91
100H	2616.99	2391.92	2214.12	96.00	1489.00	1245.00	1628.00	1678.00	116.00	128.00	24.00	87.12	46.99	35.05	17.53	103.12	55.12	20.07	9.91
106H	2769.99	2524.76	2346.96	96.00	1564.00	1320.00	1703.00	1753.00	116.00	128.00	24.00	87.12	46.99	35.05	17.53	103.12	55.12	20.07	9.91
120H	3113.99	2834.89	2657.09	96.00	1688.00	1494.00	1826.00	1876.00	116.00	128.00	24.00	87.12	46.99	35.05	17.53	103.12	55.12	20.07	9.91
135H	3440.99	3166.87	2989.07	96.00	1875.00	1681.00	2013.00	2063.00	116.00	128.00	24.00	87.12	46.99	35.05	17.53	103.12	55.12	20.07	9.91
150H	3803.99	3499.87	3322.07	96.00	2062.00	1868.00	2200.00	2250.00	116.00	128.00	24.00	87.12	46.99	35.05	17.53	103.12	55.12	20.07	9.91
84V	2094.00	1883.92	1706.12	87.00	1515.00	1280.00	1625.00	1665.00	94.00	97.00	20.00	70.10	37.08	22.10	11.94	73.41	39.88	20.07	9.91
100V	2439.00	2209.80	2032.00	96.00	1768.00	1524.00	1905.76	1955.00	116.00	128.00	24.00	87.12	46.99	35.05	17.53	103.12	55.12	20.07	9.91
120V	2881.99	2615.69	2437.89	96.00	2022.00	1828.00	2160.00	2210.00	116.00	128.00	24.00	87.12	46.99	35.05	17.53	103.12	55.12	20.07	9.91
135V	3186.94	2920.75	2742.95	96.00	2251.00	2057.00	2389.00	2439.00	116.00	128.00	24.00	87.12	46.99	35.05	17.53	103.12	55.12	20.07	9.91
150V	3511.04	3225.80	3048.00	97.00	2480.00	2286.00	2618.00	2668.00	116.08	128.02	24.00	87.12	46.99	35.05	17.53	103.12	55.12	20.07	9.91

